

# Multizone VAV Unit Control

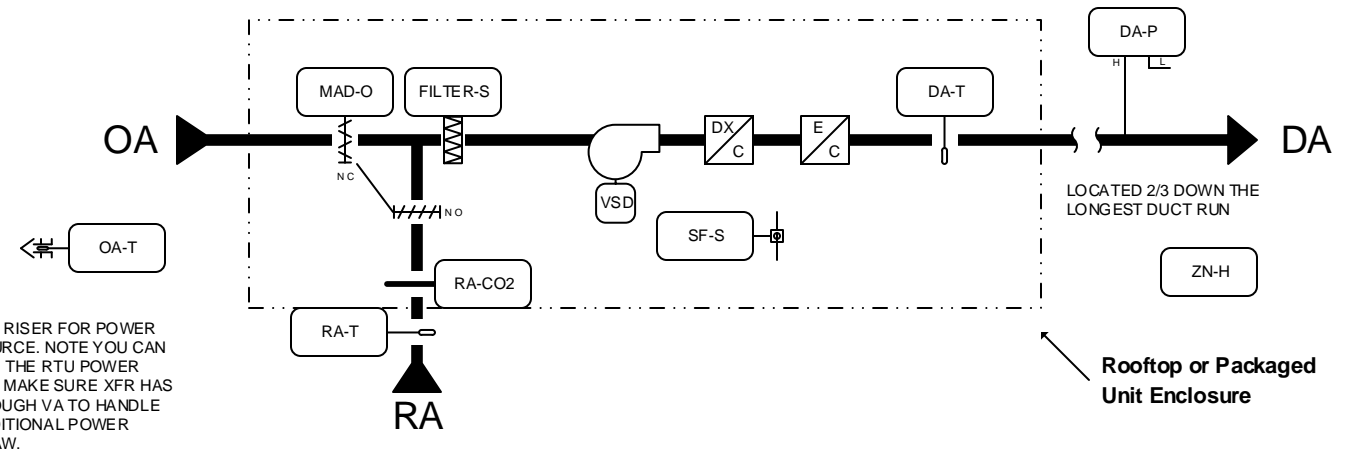
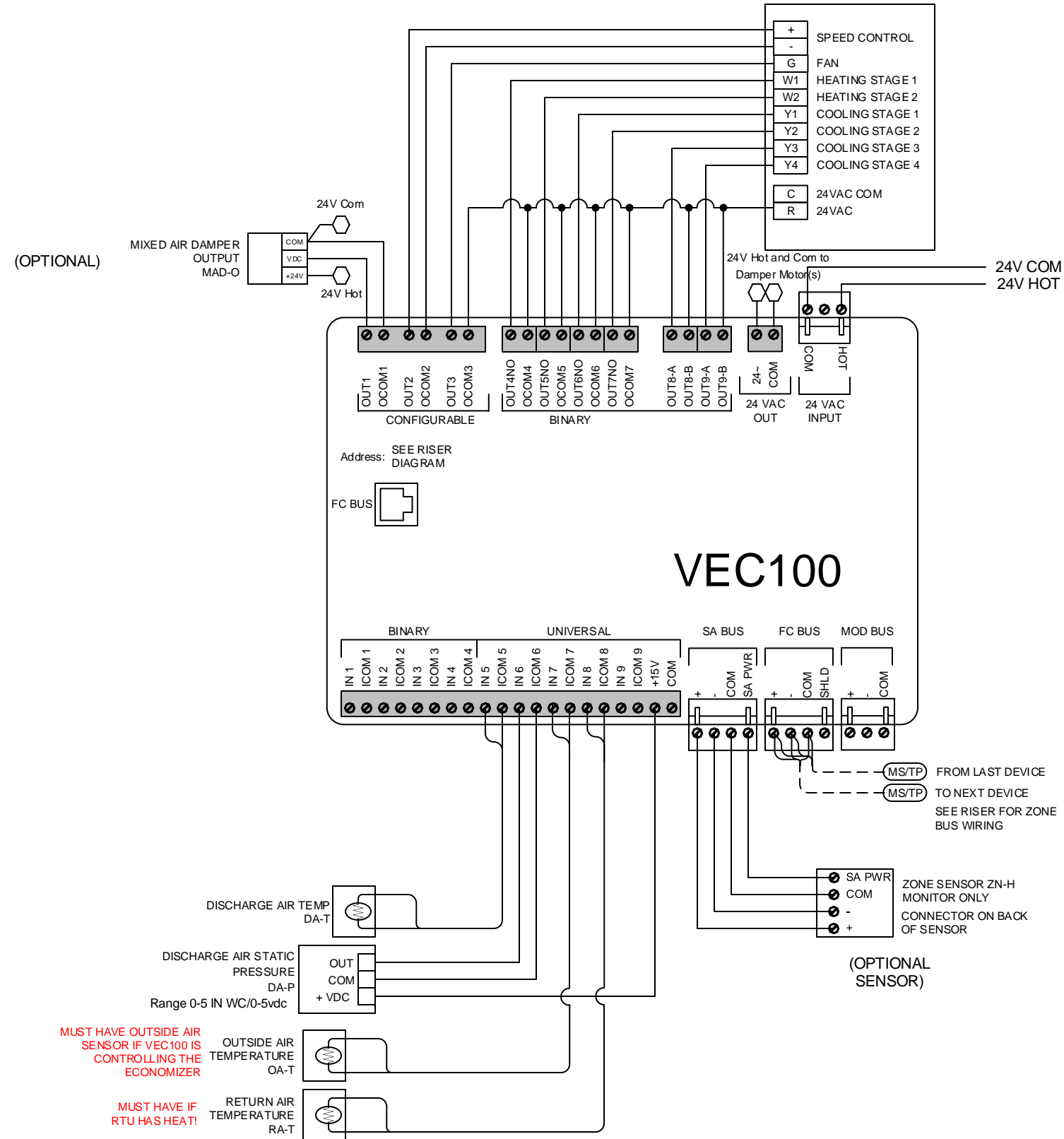

**SUPPLY FAN START/STOP:** THE SUPPLY FAN WILL BE STARTED ACCORDING TO THE SCHEDULE AND THE CONTROL SEQUENCE WILL BE ENABLED. IF THE SUPPLY FAN STATUS DOES NOT MATCH THE COMMANDED VALUE AFTER AN ADJUSTABLE PERIOD OF TIME, AN ALARM WILL BE GENERATED THIS FEATURE CAN BE DISABLED. A TOTALIZATION ALARM CAN ALSO BE SETUP TO GENERATE AN ALARM AFTER THE FAN HAS REACHED THE RUN HOURS. THIS LIMIT CAN BE USED TO SET SERVICE ACTIVITIES LIKE FILTER REPLACEMENT. SETTING THE LIMIT TO 0 WILL DISABLE THIS ALARM.

**STATIC PRESSURE CONTROL:** THE VARIABLE FREQUENCY DRIVE WILL MODULATE TO MAINTAIN THE DISCHARGE STATIC PRESSURE AT SETPOINT.

**DISCHARGE AIR TEMPERATURE CONTROL:** THE DX COOLING STAGES WILL MODULATE/CYCLE TO MAINTAIN THE DISCHARGE AIR TEMPERATURE. IF THE ECONOMIZER IS ENABLED, THEN THE MIXED AIR DAMPERS WILL MODULATE OPEN BEFORE TURNING ON STAGES OF DX COOLING. IF THE RETURN AIR TEMPERATURE FALLS BELOW AN ADJUSTABLE SETPOINT, THE RTU WILL SWITCH TO A FULL HEAT MODE IN ORDER TO PROVIDE A WARMUP CYCLE. THERE IS AN ADJUSTABLE TEMPERATURE DIFFERENTIAL ON THIS SETPOINT. IF THE CONTROLLER IS CALLING FOR COOLING AND THE DISCHARGE AIR DOES NOT DROP OVER AN ADJUSTABLE PERIOD OF TIME A COOLING ALARM WILL BE GENERATED. LIKEWISE IF A CALL FOR HEATING AND THE TEMPERATURE DOES NOT RISE OVER A PERIOD OF TIME A HEATING ALARM WILL BE GENERATED. AGAIN THESE ALARMS MAYBE TURNED OFF BY SETTING THE TIME PERIOD TO 0.

**ECONOMIZER DRY BULB SWITCHOVER:** WHEN THE OUTSIDE AIR TEMPERATURE IS BELOW THE SWITCHOVER SETPOINT, THE ECONOMIZER WILL BE ENABLED. WHEN THE OUTSIDE AIR TEMPERATURE RISES ABOVE THE SWITCHOVER SETPOINT PLUS A DIFFERENTIAL, THE ECONOMIZER WILL BE DISABLED. IF ENABLED, THE ECONOMIZER LOW LIMIT WILL MODULATE THE DAMPER CLOSED WHEN THE DISCHARGE AIR REACHES A LOW LIMIT SETPOINT. IF AT ANYTIME THE PURGE CONTACT IS INITIATED THE DAMPERS WILL BE POSITIONED WIDE OPEN.

**DEMAND VENTILATION CONTROL:** IF THE WHEN RETURN AIR CO2 SENSOR IS CONNECTED, THE MINIMUM OUTSIDE AIR DAMPER POSITION WILL BE PROPORTIONALLY INCREASED IF THE RETURN AIR CO2 RISES ABOVE SETPOINT UNTIL IT HITS THE MAXIMUM POSITION SETPOINT.

**NIGHT SETBACK/NIGHT SETUP:** WHEN IN "UNOCCUPIED" MODE, THE UNIT WILL CYCLE AS NECESSARY TO MAINTAIN THE SHARED NIGHT SETBACK ZONE TEMPERATURE AT SETPOINT. A DIFFERENTIAL PREVENTS THE UNIT FROM CYCLING EXCESSIVELY.

**SHUTDOWN:**  
 WHEN THE UNIT IS SHUTDOWN BY EITHER A STOP COMMAND OR SYSTEM SAFETY THE UNIT WILL BE SET AS FOLLOWS:  
 SUPPLY FAN WILL BE OFF  
 VARIABLE SPEED DRIVE WILL BE COMMANDED TO 0%  
 OUTSIDE AIR DAMPER WILL CLOSE  
 RETURN AIR DAMPER WILL OPEN  
 DX COOLING WILL BE OFF  
 ELECTRIC REHEAT WILL BE OFF

MUST HAVE OUTSIDE AIR SENSOR IF VEC100 IS CONTROLLING THE ECONOMIZER

MUST HAVE IF RTU HAS HEAT!

Drawing Title									
Pre-Populated Proposal									
REFERENCE DRAWING		NO.		REVISION-LOCATION		ECN		DATE	
Project Manager		Applicat on Engineer		DRAWN		APPROVED			
BY		DATE		BY		DATE			
Project Title		Branch Information		CONTRACT NUMBER					
Kmart									
		VERASYS™		DRAWING NUMBER					